

Ø"	3/8"	1/2"	3/4"	1"	1"1/4	1"1/2	2"
d	10	15	20	25	32	40	50
A	48,5	55,5	66,5	78	91	102	119
B	80	90	90	115	130	130	150
H	44	46,5	60	62,5	72	78	91,5
L	10,5	11	13	15	16	17	18
L1	8,5	10,5	12	13,5	15,5	15,5	19
gr ~	125	200	280	500	840	1.050	1.655

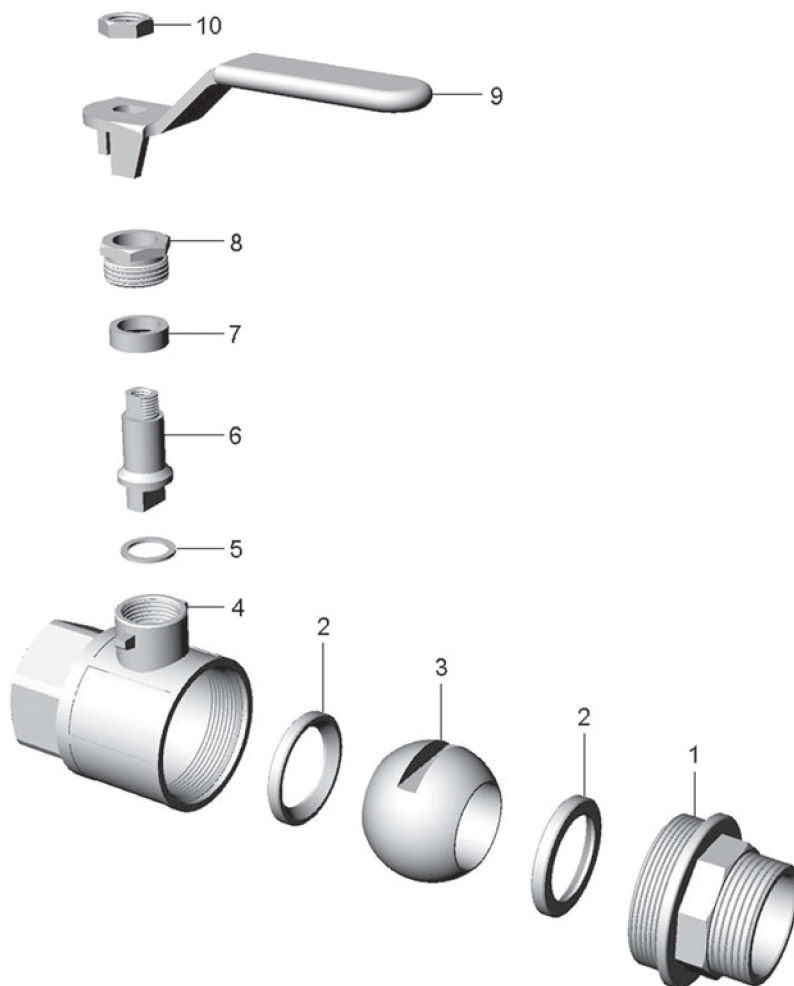
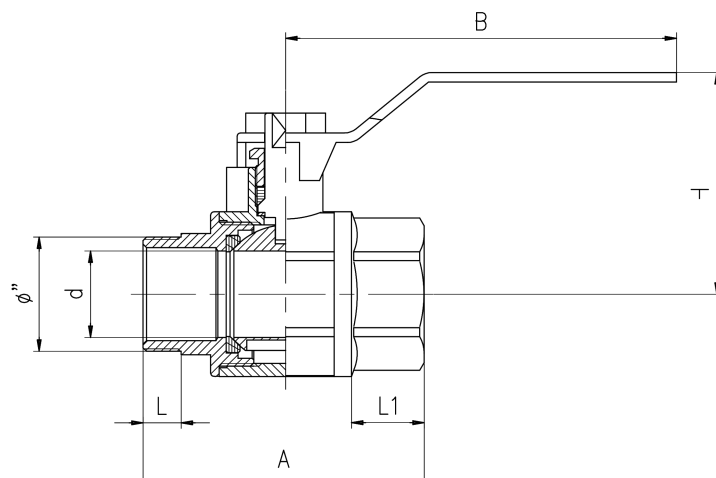

Condizioni di esercizio

Work conditions

DN	3/8" ÷ 3/4"	1"	1"1/2 - 2"
P (bar)	50	40	16
P (PSI)	725	580	230
T (°C)	-15 +80		

POS.	CODICE / CODE	DENOMINAZIONE	DENOMINATION	MATERIALE	MATERIAL
1	SOIN 3064 (DN) 001	MANICOTTO	SLEEVE	OTTONE UNI EN 12165	UNI EN 12165 BRASS
2	GTEF 3064 (DN) 002	GUARNIZIONE	GASKET	P.T.F.E.	P.T.F.E.
3	SOIN 3064 (DN) 003	SFERA	BALL	OTTONE UNI EN 12165	UNI EN 12165 BRASS
4	SOIN 3064 (DN) 004	CORPO	BODY	OTTONE UNI EN 12165	UNI EN 12165 BRASS
5	GTEF 3064 (DN) 005	ANELLO	RING	P.T.F.E.	P.T.F.E.
6	TOIN 3064 (DN) 006	PERNO	PIN	OTTONE UNI EN 12164	UNI EN 12164 BRASS
7	GTEF 3064 (DN) 007	GUARNIZIONE	GASKET	P.T.F.E.	P.T.F.E.
8	TOIN 3064 (DN) 008	PREMISTOPPA	NUT	OTTONE UNI EN 12164	UNI EN 12164 BRASS
9	SAIN 3064 (DN) 009	MANIGLIA	HANDLE	ACCIAIO	STEEL
10	DAAC 3064 (DN) 010	DADO	NUT	ACCIAIO	STEEL